

Space Ion Bar

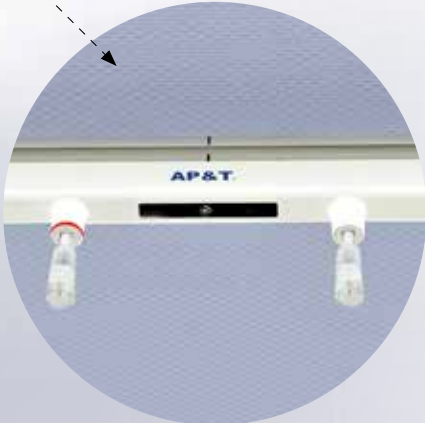

Suitable for electronics, optoelectronics, semiconductor and other industries

Effectively solve the problems caused by static electricity

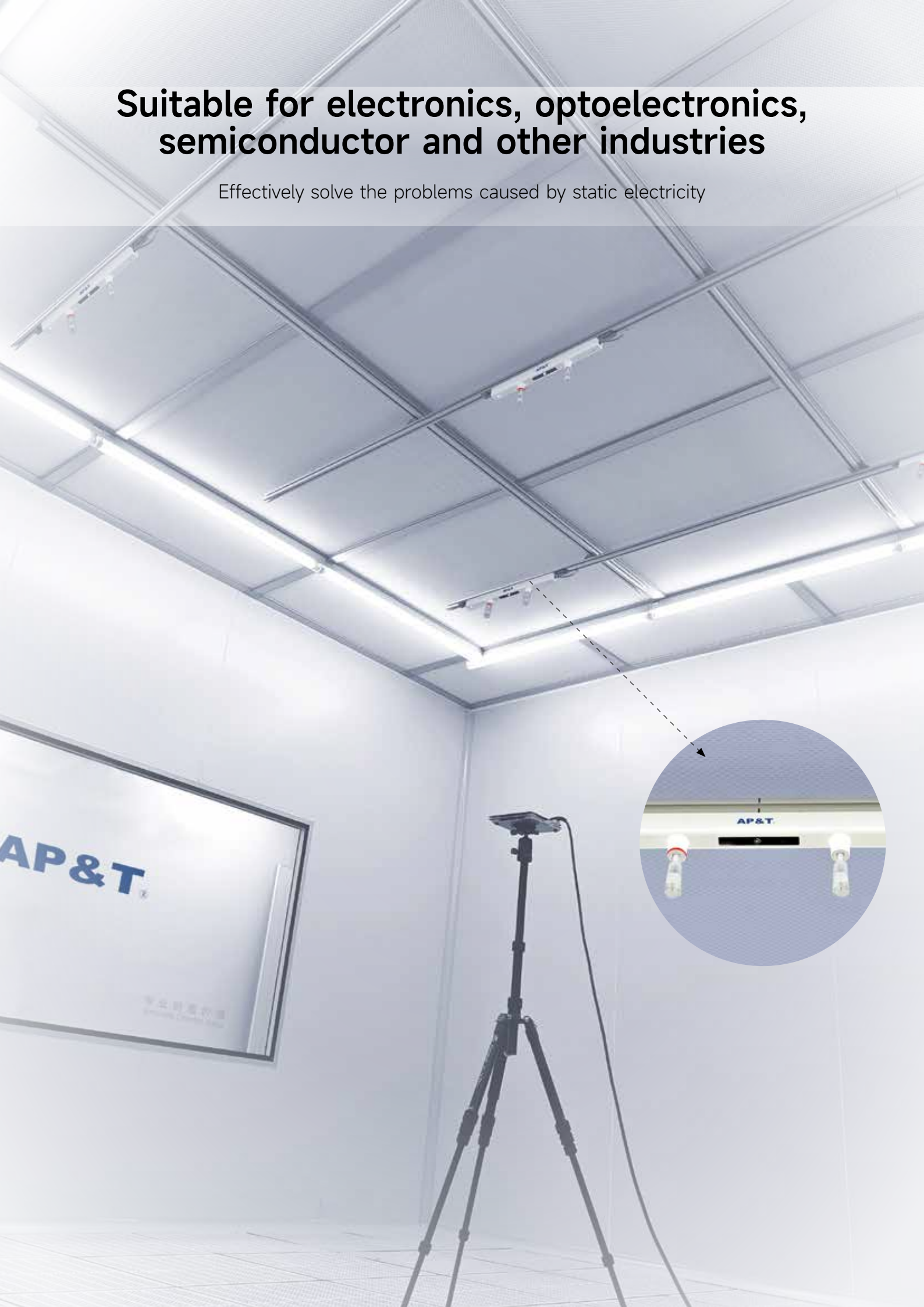

High Efficiency Static Removal

Keep a clean production environment and stay away from static electricity

AP-DB1233 Space Ion Bar is a rod-type static eliminator developed and produced by Anping Company to eliminate static electricity in clean spaces and maintain static balance in clean spaces.

The AP-DB1233 Space Ion Bar uses a DC high-voltage power supply and a special silicon-based electrode. Through alternating positive and negative DC high voltage acting on positive and negative coupled electrode needles, it generates corona discharge, ionizes air molecules, produces a large number of positive and negative air ions, neutralizes the locally unbalanced static charges in the space, achieves efficient and reliable maintenance of static balance in the space, reduces the adhesion of particles in the space, makes pollutant particles easy to be filtered out by the air conditioning purification system, and reduces particle pollution in the space.

◆ **The amplitude of positive and negative high voltage can be remotely adjusted for ion balance voltage adjustment.**

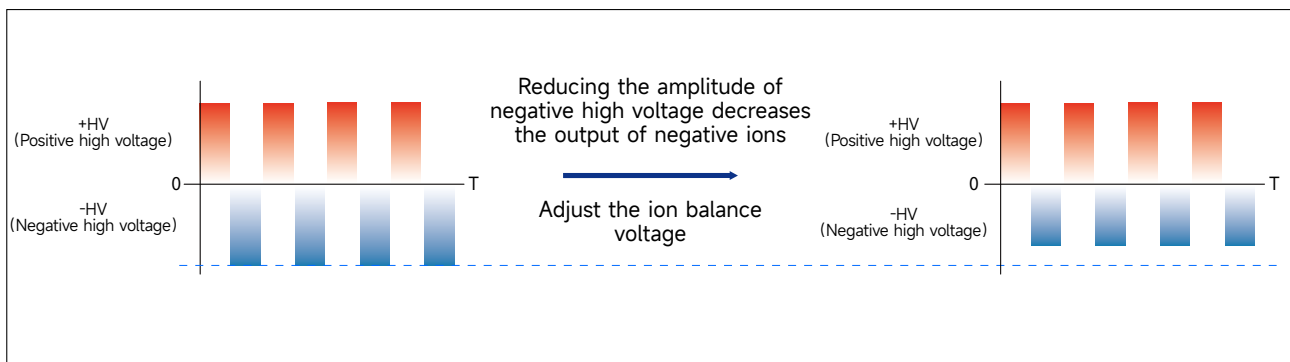
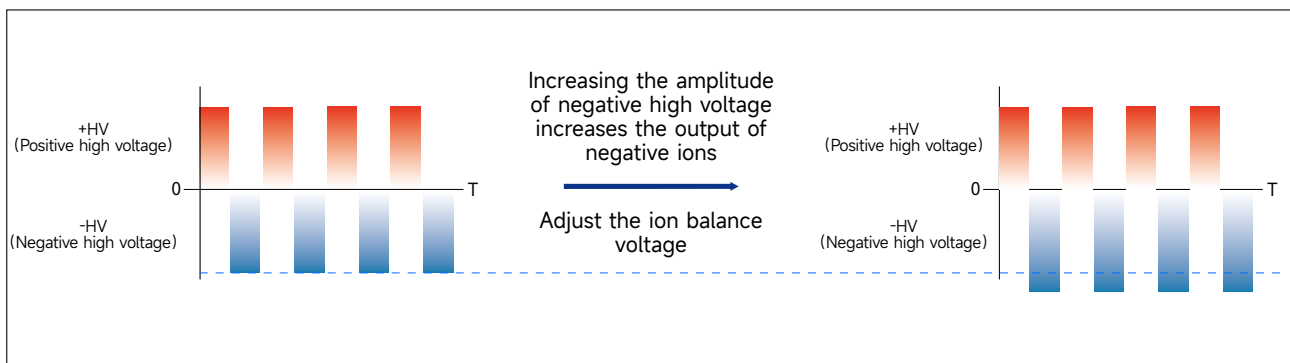

◆ Static Elimination Effect (Internal Test Version)

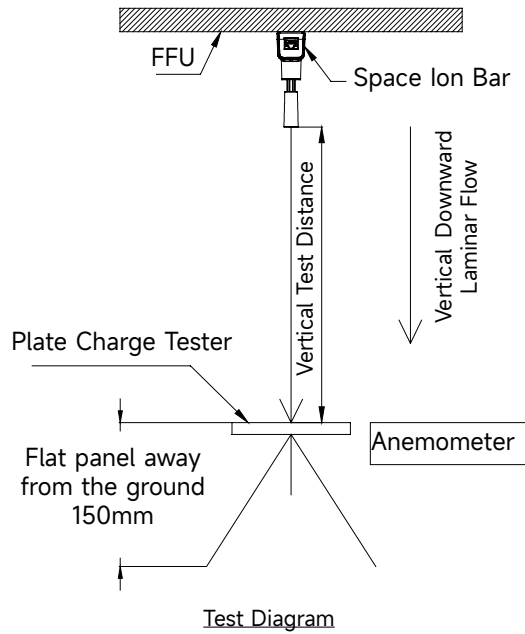

Test Standard: IEC 61340-4-7, ANSI/ESD.STM3.1, SJ/T 11446—2013

Test Instrument: Trek charge plate tester

Test Voltage: $\pm 1000V \rightarrow \pm 100V$

Test Environment: Humidity 50%RH \pm 5%RH; Temperatur 23°C \pm 3°C

HEPA (FFU) Airflow speed: 0.35-0.5m/s

Test Height: Emission Electrode Distance from Test Plate 1.8m

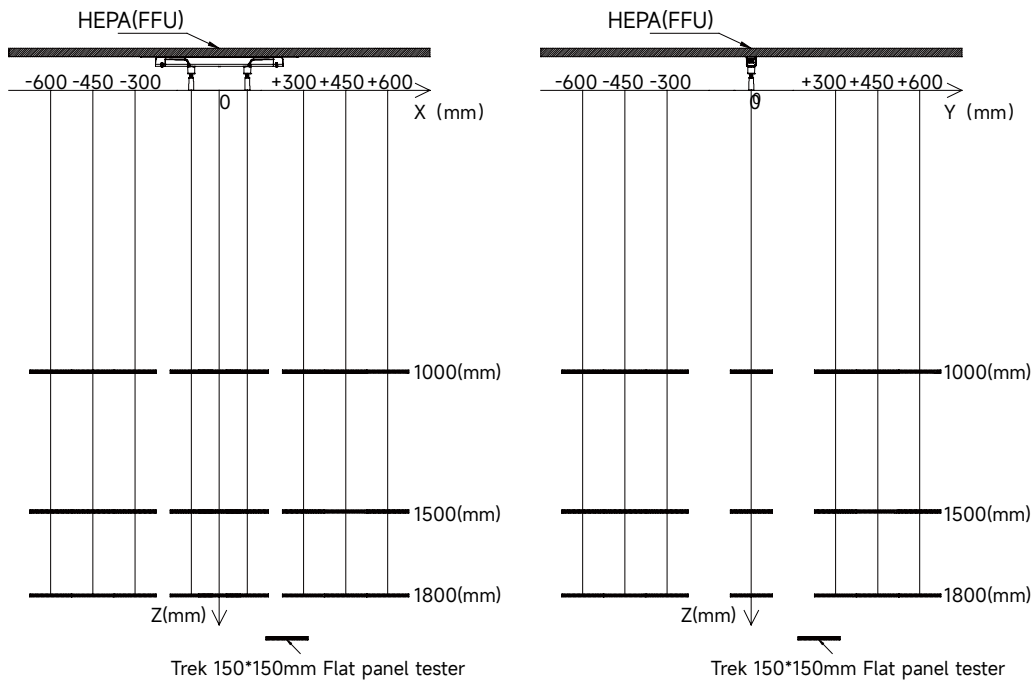

Test orientation diagram

- The following figure shows the approximate decharging coverage space size of the space ion bar within 60s:

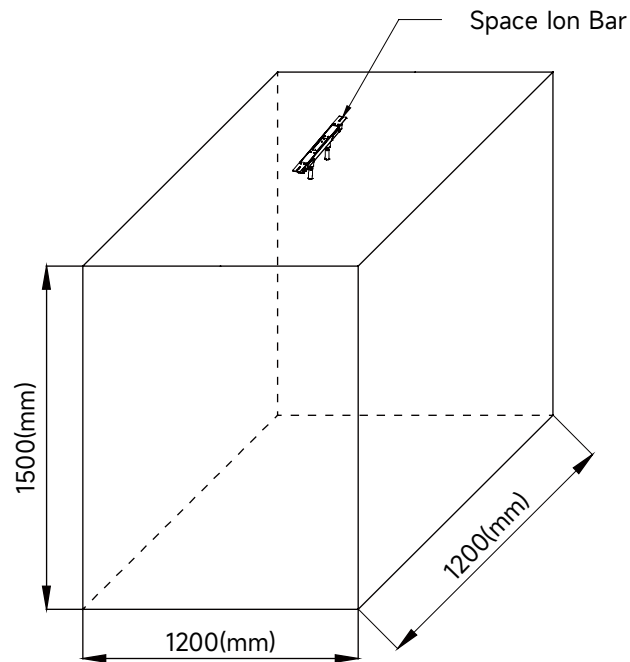

Note: The following data is for reference only. The discharge data will be different due to the different use environment and working parameters.

Test Point Location mm	+	-	MIN	AVG	MAX
X=0,Y=0	28.2	32.4	-62.6	-13.6	35.4
	30	34.1	-44.9	-1.6	42.3
	30.3	32.5	-36.2	10.9	51.5
	29.8	31.9	-36.4	6.5	49.7
	29.9	32.1	-37.6	8.4	51.2
Average	29.64	32.6	-43.54	2.12	46.02

Features

Safe / Easy to use / Durable



■ Unique discharge structure design

equipped with special Si electrodes, suitable for eliminating static electricity and charged particulate pollutants in space



■ Working status indicator

Red light alarm when high voltage is abnormal



■ Serial installation

Both ends of the product can supply power/communication, allowing serial installation, saving the number of power adapters and ion bars as well as installation workload

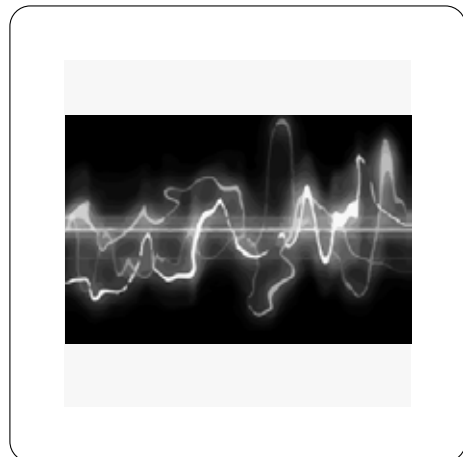

■ CE certification

It can effectively prevent the external electromagnetic interference from affecting the normal operation of the ion bar

Product Specifications

Product Details / Product Parameter / Product Size

◆ Product Parameter (Internal Test Version)

Model	AP-DB1233
Input Voltage	AC 24V
Power	1W
Output Voltage	±10KV - 20KV
Ion Emission	Pulse DC / Steady DC
Emitter Electrode	Si
Ion Bar Module	Default Component Length: 2.5 (5、10、15、24、36、60、66) inch
Ozone Concentration	< 0.1ppm (50mm From the emission electrode)
Status Indicator	Green light—Normal work, Red light—Abnormal high voltage, Blue light—Debug/Clean indicator White light at both ends of the bar - high voltage operation indicator
Status Monitoring	RS485 (115200bps,8,1,n,n) ≥ 30ms Open Collector: < 50V,100mA
Working Temperature	0°C -50°C
Working Humidity	< 70%
Dimensions	L*W*H: 455*36*33mm
Bar Material	Flame Rretardant PC
Controller	AP-SA6101 INPUT: 220VAC 50Hz / 110VAC 60Hz; OUTPUT: 24VAC 2000mA, 320*72*69mm (L*W*H)
Adapts 6-Core Power Cable	Cable length customizable
Warranty	1 Year
Certification	CE

Product Specifications

Product Details / Product Parameter / Product Size

◆ Product Details

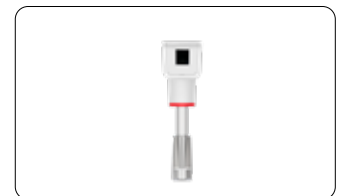

Indicator Light Functions	
Blue light	Infrared, Pause, Clean Indicator
Red light	Alarm Indicator
White light	High Voltage Working Indicator

◆ Product Size

Unit: mm

High Voltage Output Status Indicator Light

Working Status Indicator Light

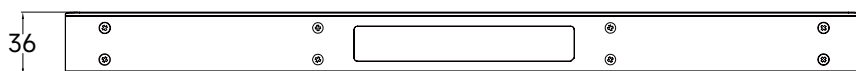
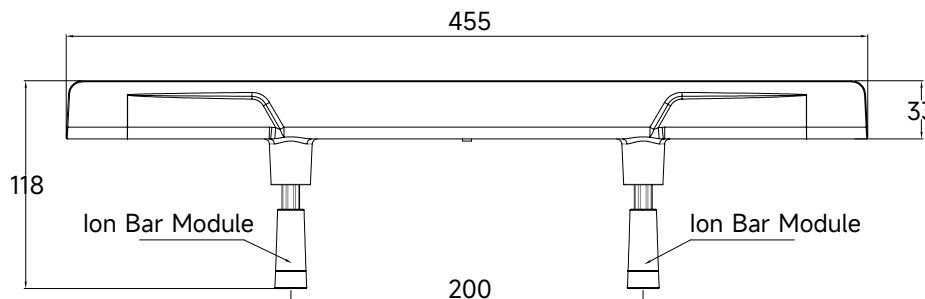
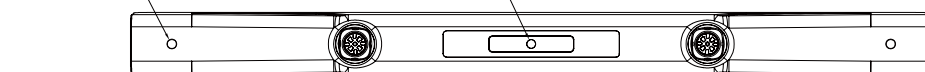

- ▶ Choose the best static elimination position / spatial layout and securely install the bar and its accompanying power adapter.
- ▶ Insert one end of the power connection cable into the RJ11 power/communication port of the power adapter, and the other end into either RJ11 power/communication port on both ends of the ion bar. The port wiring information is shown in the table below:

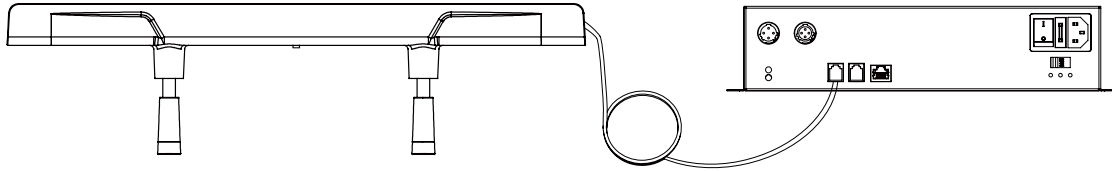

6-Core RJ11 power/communication port wiring function information		
1	Blue	HVAL High Voltage Alarm
2	Yellow	24V AC
3	Green	GND
4	Red	RS 485-B(GND)
5	Black	RS 485-A(SEI)
6	White	ACT Power On Indicator

- ▶ The green light on the bar panel and the alternating flashing white high voltage working indicator lights at both ends of the bar indicate that the ion bar is working normally.
- ▶ **The power adapter size illustration is as follows:**

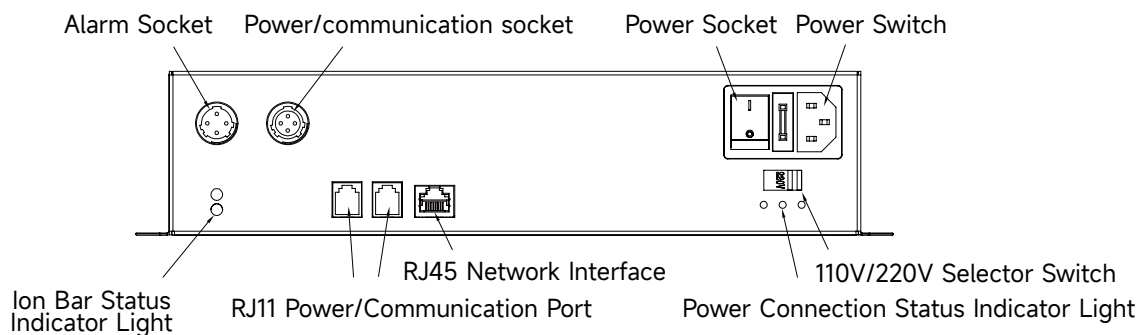
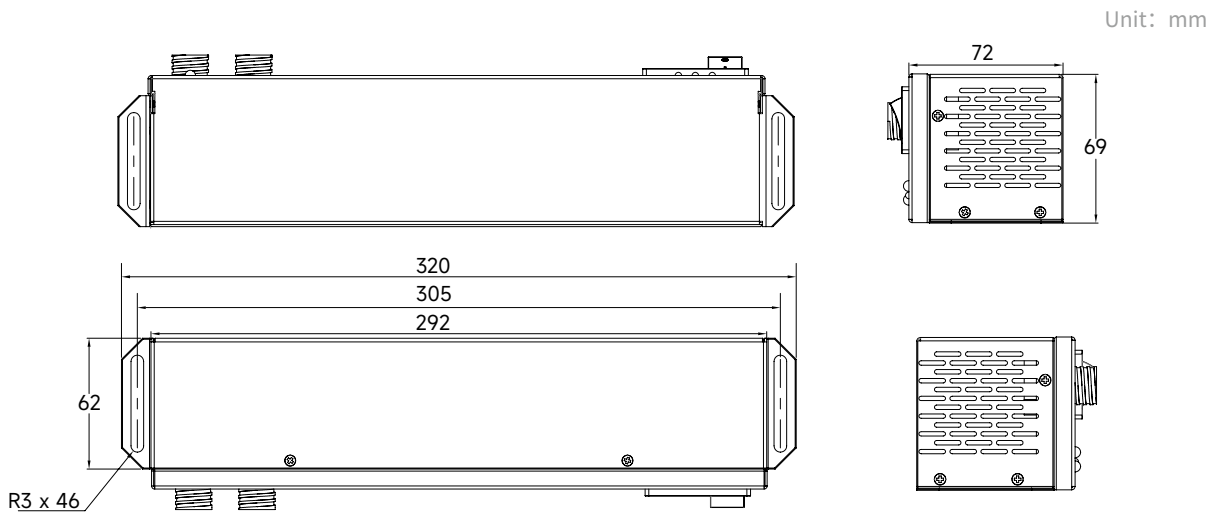

► The wiring information diagrams for the alarm socket and the power/communication socket are as follows:



The wiring information diagrams for the alarm socket			The power/communication socket are as follows		
A1	Green	COM	1	Green	GND
A2	Red	AL_OUT	2	Red	RS485+B
A3	Black	ACT_OUT	3	Black	RS485+A
A4	White	24V DC	4	White	24V AC

Note: Each power adapter can load up to 20 space bars. The 6-core port wiring information is the same as the table above.

◆ Remote Control Instruction



► Basic Functions of the Remote Control:

Remote Control Function Description (Internal Test Version)	
Function	Operation Instructions
Power On/Off	Press and hold the power button for 3s to turn on, press and hold for 3s again to turn off, or it will automatically turn off after 120s
Start/Stop	Select "Start/Stop" and press the select button to confirm; then press the up/down buttons to choose pause/start
Adjust Frequency	Select "Frequency" and press the enter button to confirm; then press the up/down buttons to adjust the frequency parameters
Adjust Cleaning Time	Select "Cleaning Time" and press the enter button to confirm; then press the up/down buttons to adjust the cleaning time parameters
View Status	View the current device running status information
Positive High Voltage Setting	Select "Positive High Voltage Setting" and press the enter button to confirm; then press the up/down buttons to adjust the positive high voltage parameters Note: Available only to advanced users, regular users can only query
Negative High Voltage Setting	Select "Negative High Voltage Setting" and press the enter button to confirm; then press the up/down buttons to adjust the negative high voltage parameters Note: Available only to advanced users, regular users can only query

Working Mode	Select "Working Mode" and press the enter button to confirm; then press the up/down buttons to choose the working mode: Steady DC / Asynchronous Pulse / Synchronous Pulse Note: Available only to advanced users
Firmware Version	View the firmware version number Note: Available only to advanced users
Set Device Address	Select "Device Address" and press the enter button to confirm; then press the up/down buttons to set the device address
Main Model	Query the current device model
User Level	Hold the select confirm button, then hold the return button, wait for 5s, and switch the user level

◆ Communication Connection



◆ Technical Tips

- When using the ion bar, it should be placed in the working area where static electricity needs to be eliminated and charged particulate pollutants controlled. The installation angle should be vertical.
- The discharge electrode of the ion bar should be at least 10cm away from metal conductors and metal grounding bodies, and the bar must be reliably connected to the grounding wire.
- To better achieve the balance of positive and negative ions in the entire area, the layout of the ion bars should alternate between positive and negative electrodes. The positive electrode rods are marked with red ring stripes.
- To ensure the static elimination performance of the ion bar, the airflow speed is recommended to be between 0.3 and 0.5m/s.
- The following factors will affect the performance of the space ion bar to varying degrees:

a. Electrode needle near grounded conductor	j. Low-speed laminar airflow
b. Electrode needle removed or covered	k. Space ion bar not installed at the corresponding laminar flow hood
c. Electrode needle near temporary partitions or curtains	l. Plate charge tester near large grounded conductor
d. Electrode needle corona blocked by attachments	m. Plate charge tester placed on production equipment/workbench/tools (inside)
e. Other ionizing equipment nearby	n. Plate charge tester too far from space ion bar (electrode needle) test
f. Ionizing equipment near the test turned on or off during testing	o. Space ion bar positive and negative high voltage output too low
g. Space ion bar in a large open area	p. Space ion bar working parameters cannot be controlled
h. Unstable non-laminar airflow	q. Space ion bar alarm
i. Strong cross airflow	r. Space ion bar no power supply

▲ Safety warning



- Please read the instruction manual carefully before installing and using this equipment.
- The whole set of equipment must be reliably grounded during use, otherwise it is easy to cause abnormality or even damage to the ion bar.
- Do not use this equipment in environment where humidity is > 70%.
- It is strictly forbidden to use this equipment in flammable and explosive environments.
- Unauthorized disassembly of the product is strictly prohibited, internal maintenance and repair must be performed by professionals.
- The product is strictly prohibited to touch liquid during use, otherwise an abnormality may occur and cause electric shock or fire.
- When connecting, disconnecting, inspecting, or replacing the ion bar, the power must be turned off first, otherwise electric shock, fire, and equipment damage may occur.
- Power to the ion bar should not be cut off by removing the cable to avoid equipment damage.
- The laminar flow gas for the product should be dry, clean air or nitrogen. If the gas source contains moisture or grease, it will cause the product to malfunction or be damaged.
- The product is designed specifically for static elimination and must not be used for other purposes. Any abnormal use may cause machine failure, electric shock, or fire hazards.
- When powered on, it is strictly forbidden to touch the electrode needle, as it may cause malfunctions and electric shock accidents.
- The discharge needle is a sharp and fragile item, please handle it carefully.
- Before powering on the product, please check the specifications of the power supply. Any non-compliant power supply will cause the product to malfunction or even damage.
- Please regularly check the product's power and communication lines. If damaged, replace them immediately to avoid electric leakage, poor communication, and abnormal operation.

▲ Trouble shooting

NO.	Problems	Reasons	Solutions
1	The indicator on the label panel is off	Poor contact of the power cable	Check whether the power cable is in good condition and securely connected
		Power supply mismatch	Confirm the power supply specification (INPUT: 220VAC 50Hz / 110VAC 60Hz; OUTPUT: 24VAC 2000mA)
2	The white high-voltage work indicator lights at both ends of the bar are not on (flashing with the positive and negative high-voltage on/off)	Poor contact of the power cable	Check whether the power cable is in good condition and securely connected
		Power supply mismatch	Confirm the power supply specification (INPUT: 220VAC 50Hz / 110VAC 60Hz; OUTPUT: 24VAC 2000mA)
		No power supply, white indicator light is off	Check the power supply cable
		Mainboard abnormal - white indicator light is off	Return to factory for maintenance
3	The electrostatic removal performance decreased	Discharge needle is polluted and damaged	Clean or replace the discharge needle
		Whether the discharge seat is tightened	Confirm the discharge seat is tightened
		Bearing set of ion bar is improper	Confirm the best bearing set
		There are conductors or other ion bar around	Remove (moving) conductors or other ion bar
4	Panel indicator red light on	Electromagnetic interference	Turn off the power switch / unplug the power cable, restart the ion bar
		Abnormal discharge	Confirm the installation location and stay away from surrounding conductors, confirm whether the electrode needle is close to or touching the metal conductor and remove foreign objects
		No power supply for high voltage module	Return to factory for maintenance
		High voltage module is damaged	

5	Unable to discharge	High voltage module is damaged	Return to factory for maintenance
		Main-board chip is damaged	
		Main-board chip is damaged caused by poor grounding or no grounding	Check the grounding of the ion bar and plant equipment, and return to the factory for maintenance

◆ Packaging accessories

Name	Picture	Part No.	Specification	Quantity
Mounting Bracket		AP8038045	Length 90mm / Width 34mm / Thickness 2mm SUS304	Optional
Power Connection Cable		8HXK00600	Customized as needed	NA
National Standard Power Cable		8YXG25110	Standard 1.8m, optional 3m/5m	1

▲ Maintenance

- ▶ Particulate pollutants in the environment will adsorb onto the electrode needle, significantly increasing the rate of electrode needle contamination. To ensure the good performance of this product, it should be cleaned and maintained in a timely manner according to the usage environment and static protection requirements, that is: unscrew the discharge electrode assembly (discharge needle seat), place it in an ultrasonic cleaner, and perform ultrasonic cleaning for 10 minutes. Ultrasonic cleaning will remove the contaminant particles attached to the electrode needle and most of the white crystalline deposits. After cleaning, its static elimination performance will be significantly improved. Note:

A. Operation must be done 10 minutes after power cut off.

B. The ultrasonic cleaning liquid should be pure water, and corrosive solvents such as circuit board cleaners should not be used, otherwise the discharge electrode assembly (discharge needle seat) will be corroded.

C. The ion bar must be powered on after moisture is completely volatilized after cleaning.

- ▶ If the bar panel indicator light and the white high-voltage working indicator lights at both ends of the bar are off, stop using it and have it inspected and repaired by professional maintenance personnel. It can only be used after the electrical performance indicators are normal.

▲ After-sales service

- ▶ Before leaving the factory, the AP-DB1233 space ion bar undergoes rigorous testing and aging treatment, and its performance fully meets the relevant indicators marked in the user manual.
- ▶ AP&T makes a commitment to the customer that any defective parts inspected by AP&T will be repaired or replaced free of charge within one year from the date of purchase. However, this commitment does not apply to:
 - (1)、Equipment is used or installed incorrectly.
 - (2)、Damage caused by negligence or accident during use.
 - (3)、Unauthorized modifications, disassembly, or repairs by other service departments not authorized by Anping Company.
- ▶ The discharge electrode is a consumable product which is not included in the scope of warranty and will be charged for replacement when repairing.
- ▶ AP&T shall not be liable for any incorrect use of the products except for repair or replacement of parts as specified above.

AP&T®

AP&T®

SPECIALIZATION CREATION VALUE

Professional electrostatic intelligent monitoring/analysis
and elimination solution provider

Shanghai Anping Static Technology Co.,Ltd

Tel: 021-6451 7676

Website: www.ap-static.com

Address: 3-4/F, Building 27, No.69, Guiqing Road, Shanghai, China

