

Intelligent Self-Balancing Static Elimination Ion Bar

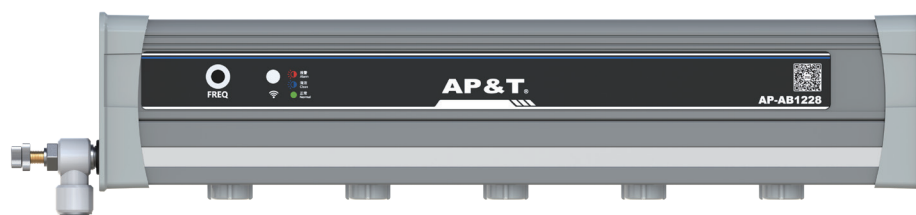

Suitable for electronics, optoelectronics, semiconductor and other industries

Effectively solve the problems caused by static electricity

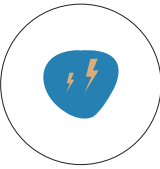
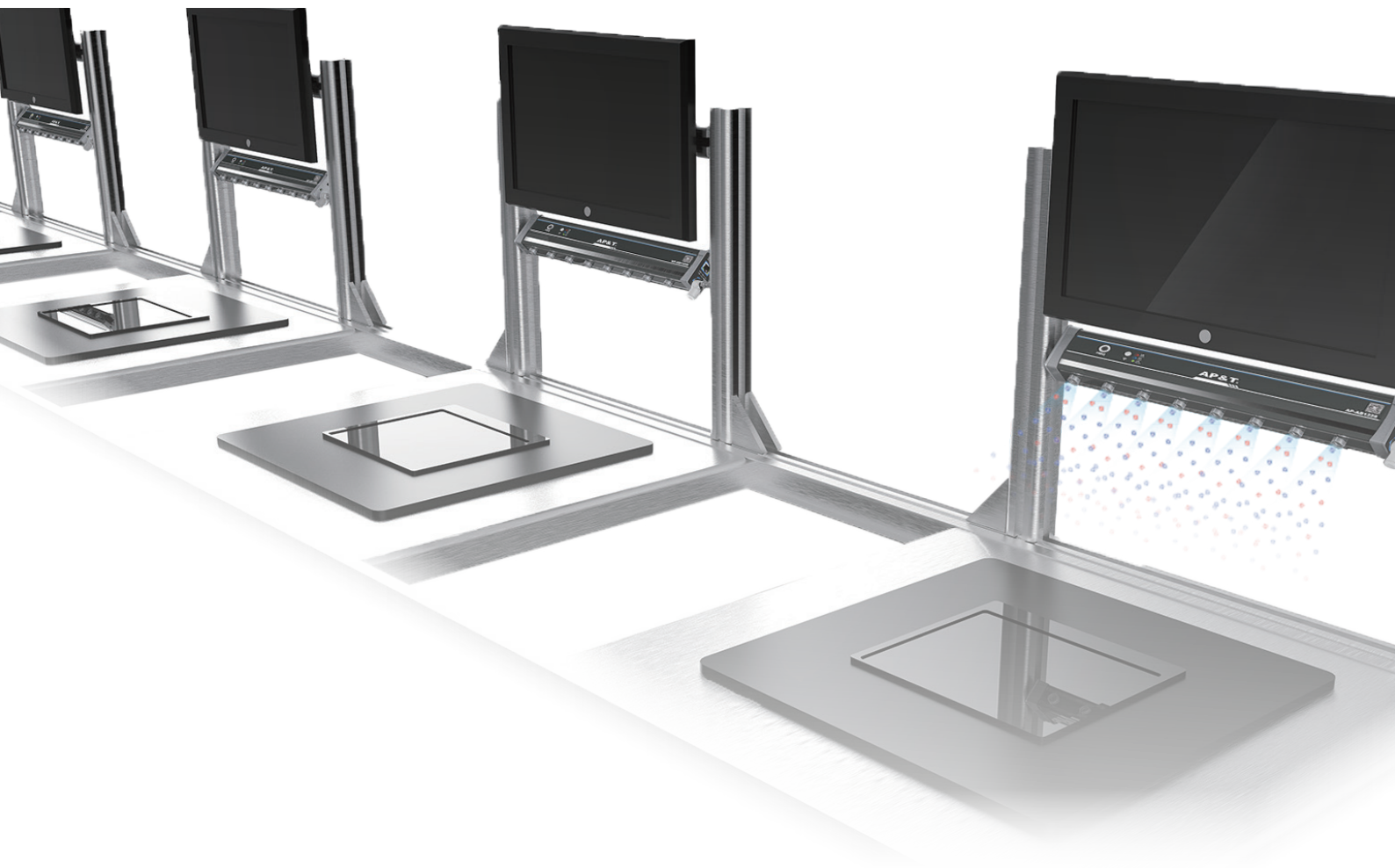

Static removal

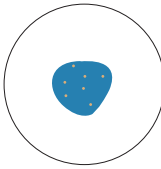

Prevent adhesion of objects

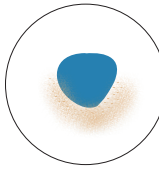

Prevent material splash

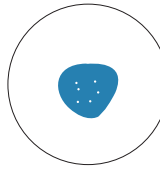

Prevent static electricity

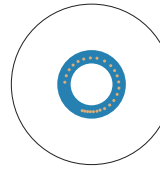

Prevent blockage of feeder

Intelligent Remote Control

Discharge speed is two times compare to traditional structure

◆ Product Profile

AP-AB1228 air source anti-shock pulse AC ion bar is the bar type static elimination device that is developed by shanghai anping static technology co., ltd. for eliminating the static on the surface of objects.

AP-AB1228 air source anti-shock pulse ac ion using dc high voltage power supply, adopts special alloy electrode to act on coupling electrode pins through positive,negative DC high voltage alternately, That is, DC high power source uses AC implementation to act on the electrode needle by coupled devices, producing corona discharge, air molecules are ionized to produce large amounts of positive, negative air ions and the compressed air is transported to the surface of the electrostatic object to neutralize the positive, negative charges for the high efficiency and reliability of eliminating the static on the surface of the object.

Discharge speed is **2** times
compare to traditional
ion bar

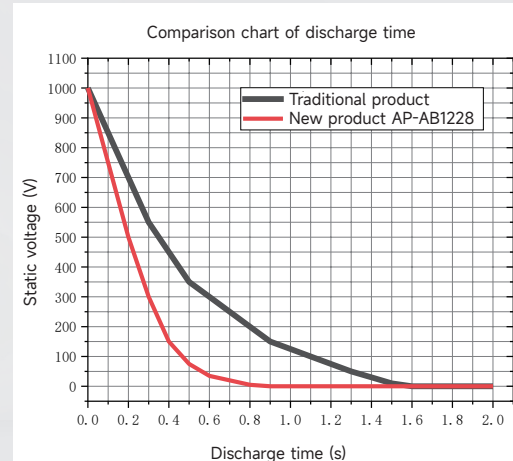
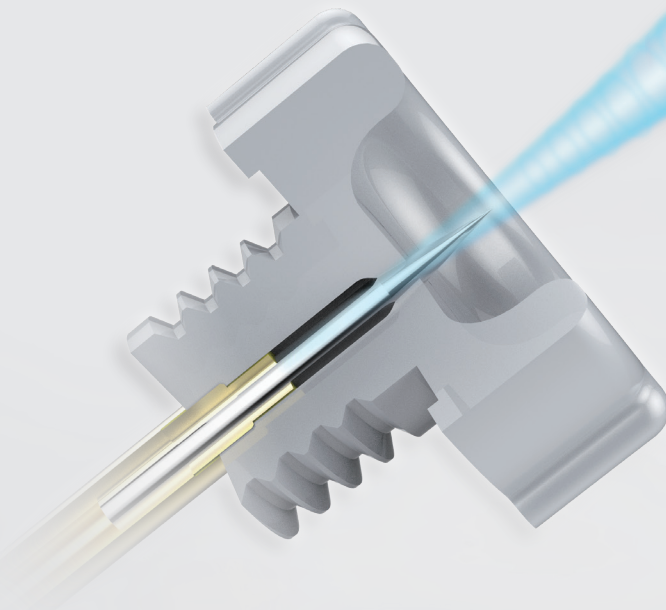

Intelligent networking

Multiple networking methods to monitor the working status of ion bar online

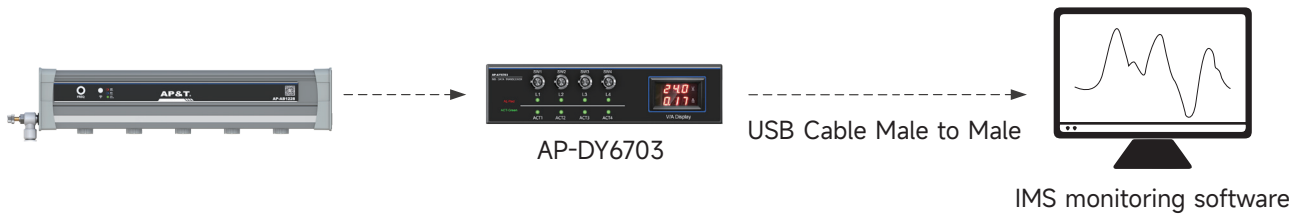
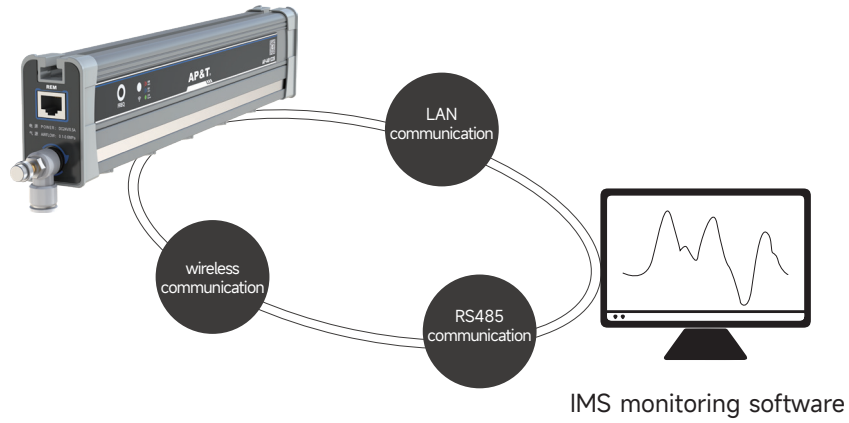

Intelligent Remote Control

Ion balance / ion output frequency adjustable

◆ The output ratio of positive and negative ions is adjustable, which can be used to adjust the ion balance voltage.

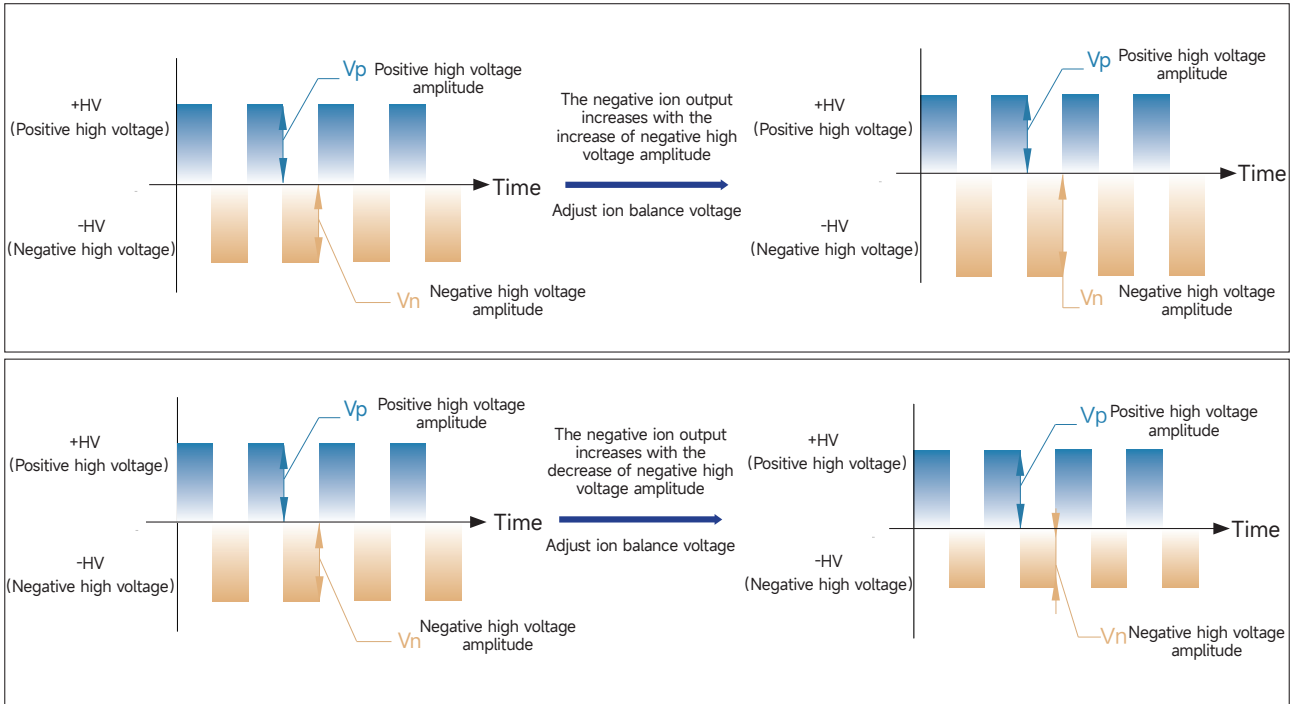

◆ The output frequency of positive and negative ions is adjustable, which can be applied to different discharge distance to achieve faster discharge speed.

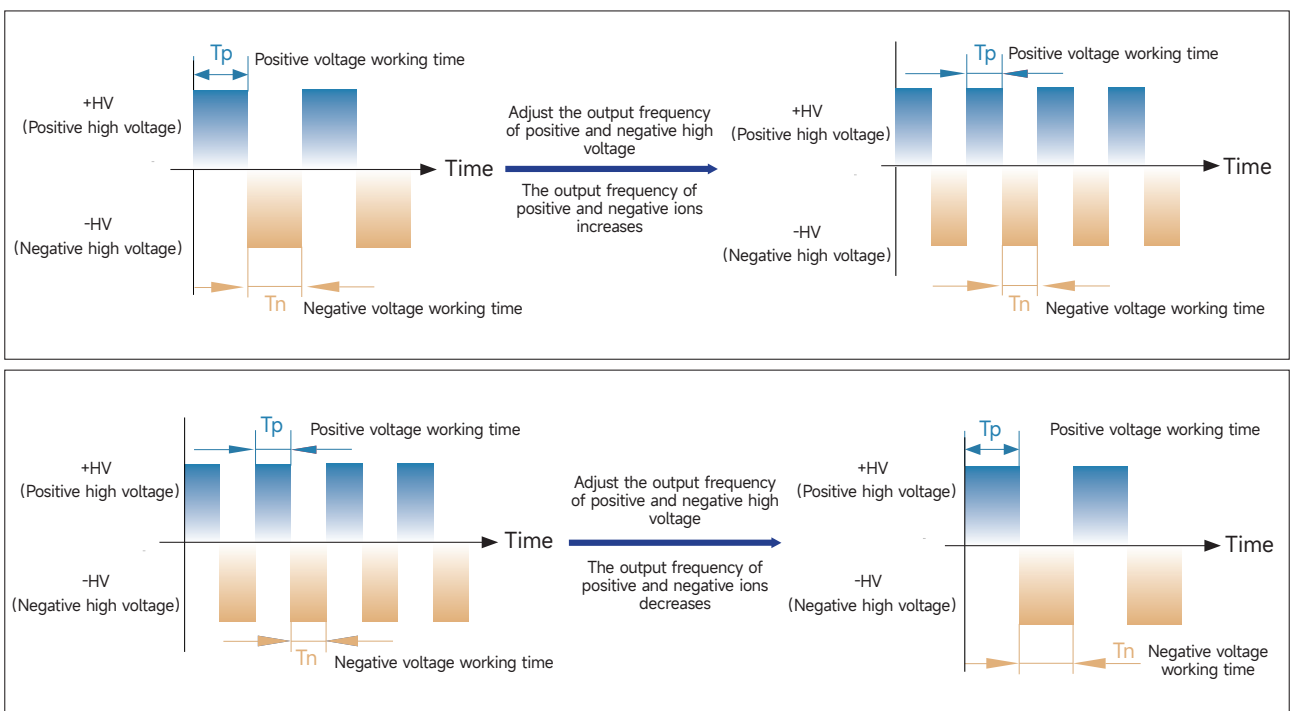

Intelligent Remote Control

Ion balance/ion output frequency adjustable

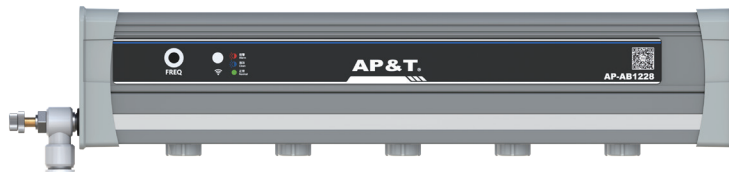

Button Function instructions		
Function	Symbol	Operation instructions
Unlock		Unlock before adjusting operating parameters.
Run / Pause		Device starts running when power is on. Press "STOP" to standby and no high voltage output. Press "RUN" again and the device will start working.
Adjust cleaning cycle	CT _{TH} → +/-	<ol style="list-style-type: none"> Turn on the cleaning alarm function (Refer to the operation instructions of the cleaning alarm function) Press CT_{TH}, Then +/-, to increase or decrease the cleaning time cycle The cleaning cycle adjustment can be adjusted from 1-60 days, the default setting is 15 days, the blue flashing cleaning alarm would be executed after the set cleaning time cycle ends(0 days) *Note: as the default cleaning alarm function of the product is off, If cleaning cycle is required to adjust, you need to turn on the cleaning alarm function firstly.
Cleaning alarm function	Unlock → 5 → OK	Turn on the cleaning alarm function: <ol style="list-style-type: none"> Remote Control: Unlock---5---OK Product indicator light changes: white light short on 1s into green light On 5s,Finally into blue light flashing After the indicator light blinks blue, Please power off to re-start the product for releasing the state After powing on,It's ok for the indicator light in green always on Close the cleaning alarm function: <ol style="list-style-type: none"> Operate the remote control: Unlock---5---ok Indicator light changes: From white light short on 200ms into a constant green light
Adjust ion balance voltage	IB _N → +/-	Press IB _N first, then press + when the positive voltage on flat panel detector or discharge object surface is high, press IB _N first, then press - when the negative voltage on flat panel detector or discharge object surface is high until the ion balance reaches the ideal status.
Adjust frequency	FREQ → +/-	Press FREQ first, then press +/- to increase or decrease the frequency of positive and negative ions output .
Confirm	CAL → OK	Note: Press CAL first, then press OK to confirm after adjusting the output parameter; otherwise,false alarms are likely to occur.

Pulse AC

The effect of static eliminating is better compare to power frequency AC ion bar

◆ Pulse AC VS traditional AC

The pulsed AC method alternately applies "+" and "-" high voltage to one electrode needle to generate two polar ions.

Compared with the AC method, the ion generation efficiency is higher. Electrostatic elimination ability can be fully plated on matter for short or long distance. Beside, frequency adjustable so the working distance is extended. Positive and negative ion output ratio adjustable so easy for intelligent control.

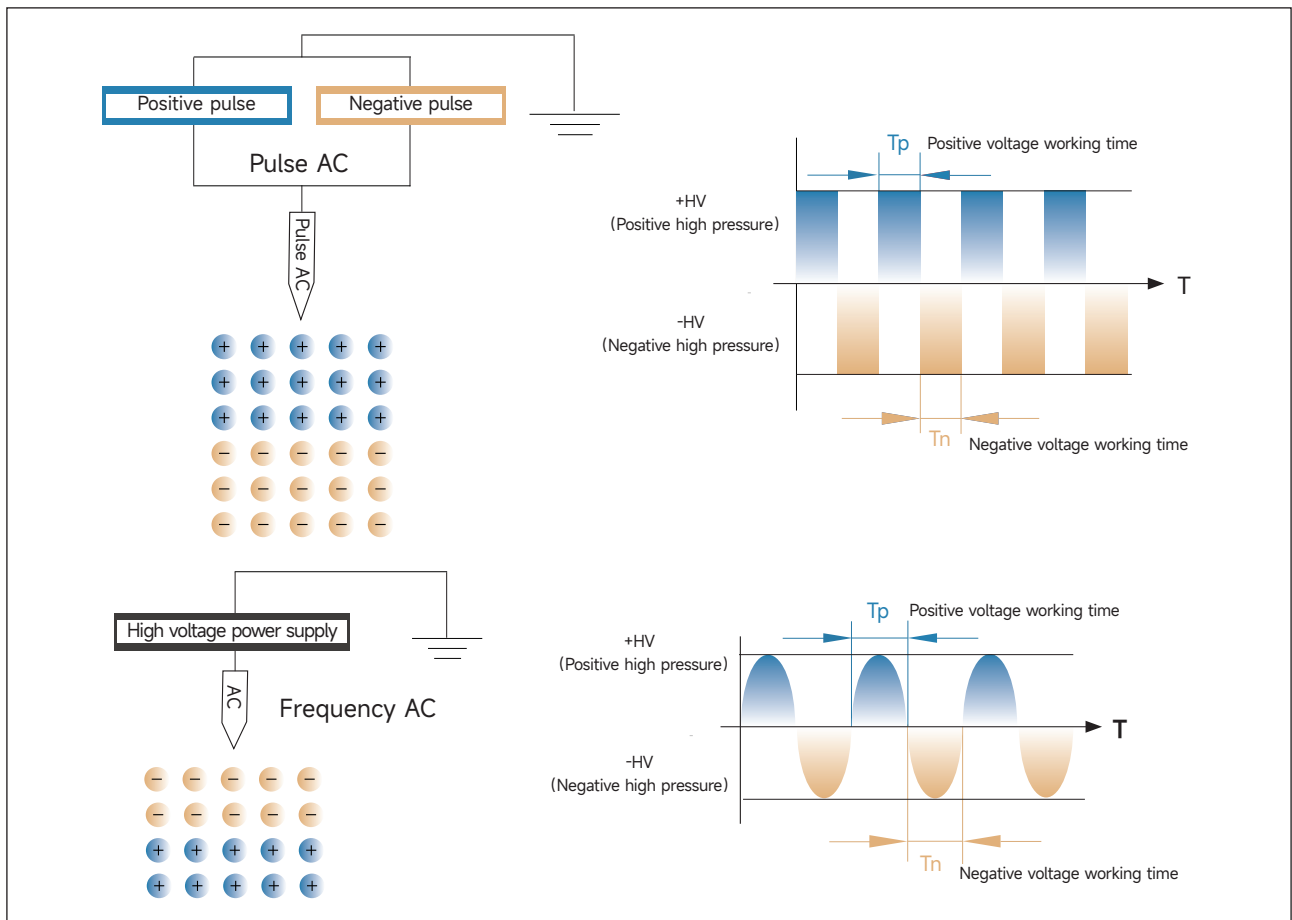

◆ 3 situations of static electricity on the surface of the object

- 

Adjust the TP smaller to have smaller positive voltage acting ability and shorter acting time, positive ion outputs become less, negative ion outputs become more, to neutralize the extra positive charges on the surface of the objects.
- 

Adjust the TP larger, to have larger positive voltage acting ability, longer acting time, Positive Ion outputs become more, negative ion outputs become less to neutralize the extra negative charges on the surface of the objects.
- 

Adjust the duty factor $\{TP/(TP+TN)\}$ into the appropriate ratio, to provide the same amounts of positive, negative ions for neutralizing the static charges on the surface of the objects.

High Efficiently static removal

Stay away static trouble & for clean production environment

Discharging time: Discharge speed within 2 sec when distance is 300mm

Discharging distance: Up to 300mm width.

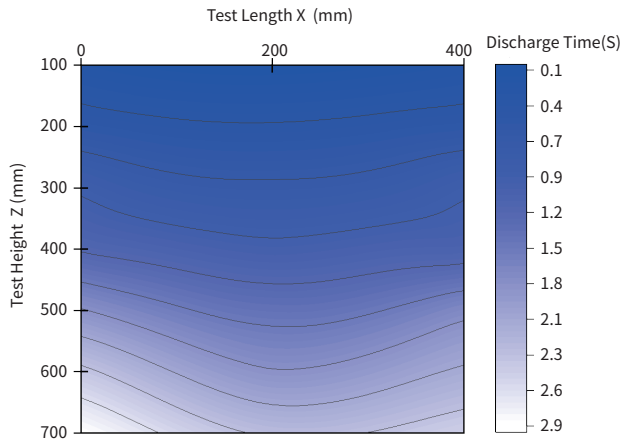

Discharge time distribution diagram of AP-AB1228 with 500mm bar length at 0.3MPa air pressure

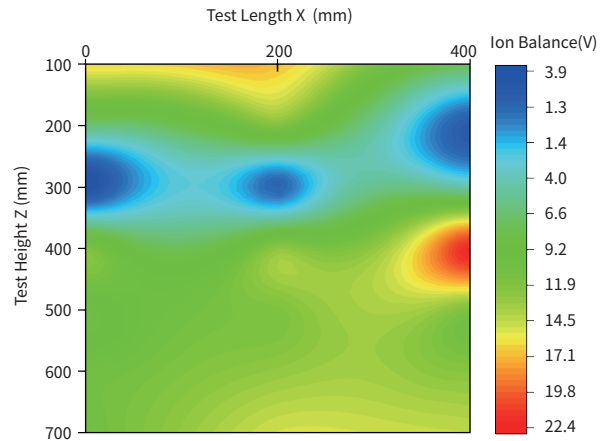

Ion balance voltage distribution diagram of AP-AB1228 with 500mm bar length at 0.3MPa air pressure

Test standard: ANSI/ESD.STM3.1, SJ/T 11446—2013

Test instrument: Trek charge flat panel tester

Test voltage: $\pm 10000V \rightarrow \pm 100V$ attenuation

Test environment: Humidity $50 \pm 5\%$; Temperature $23 \pm 3^\circ C$

The test orientation diagram shown below:

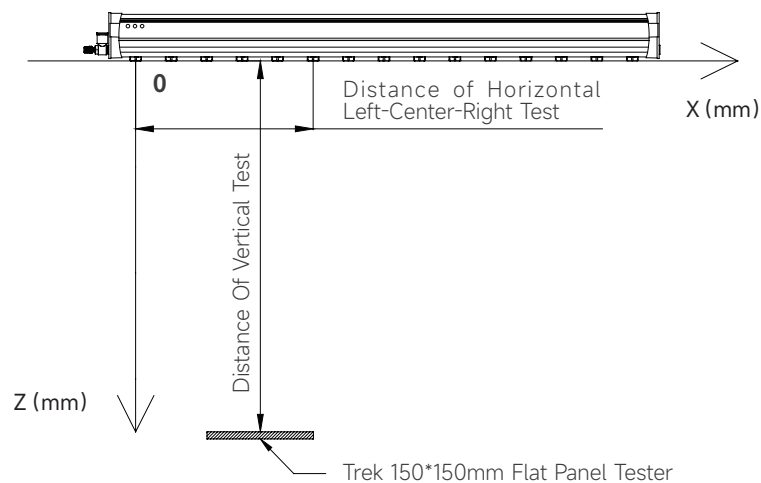

Note: When tested at both ends, the edge of the plate is aligned with the first and last electrode points of the left and right ends of the ion bar.

Features

Safe / Easy to use / Durable



Electric shock proof

Avoid injuries from accidental human contact.



Discharge parts replaced easily

Easy to replace, standard configured tungsten needle, long time ionization ability.

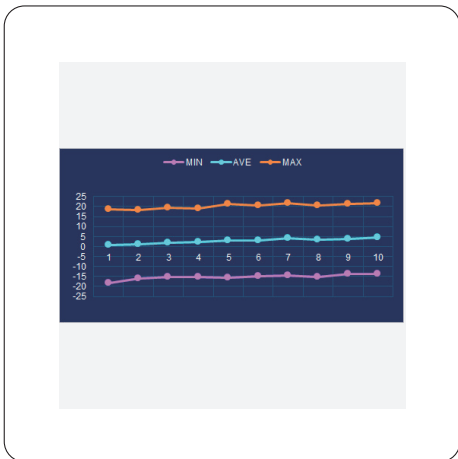

Low balance voltage, excellent balance reliability

1. Unique discharge structure and maintain excellent balance voltage (selfbalancing) through balance feedback circuit, which can extend the cleaning cycle of electrode needle.
2. Peak voltage less than $\pm 50V$.



It's convenient to replace the discharge components

It can be replaced by rotating the needle holder at counter-clockwise direction when the discharge needle is damaged and required for replacement.

Features

Safe / Easy to use / Durable

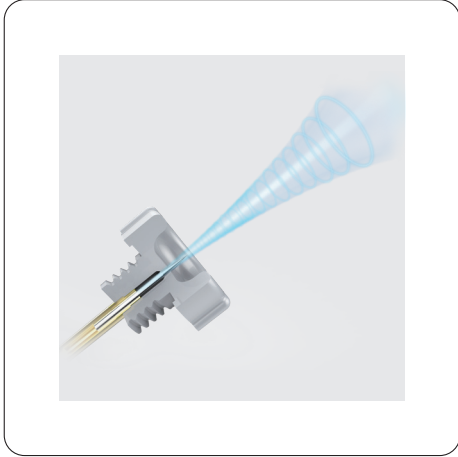

■ Airflow acceleration structure

Ion nozzle has airflow acceleration structure which can realize 2 times discharge speed more than traditional structure.



■ Intelligent remote control

Adjust ion balance and output frequency.

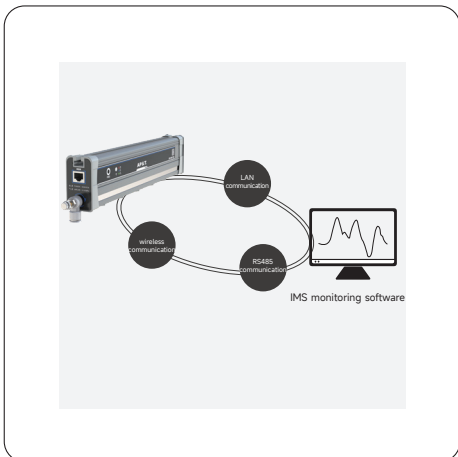

■ Network monitoring

Wired network communication realisable and monitor the working status of the ion bar.



■ CE certification

It can effectively prevent the external electromagnetic interference from affecting the normal operation of the ion bar. This is a static electricity eliminator with high safety and high reliability.

Product Specifications

Product Appearance / Product Parameter / Product Size

Product Appearance

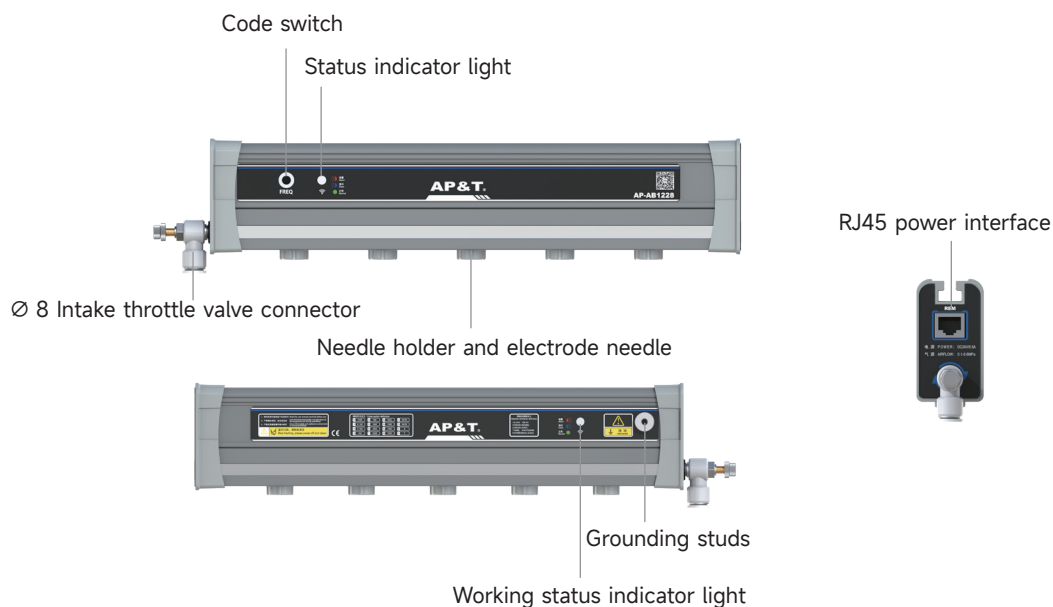

Setting information of operating frequency coding switch	Network port cable function information		RJ45 interface
0; Pause (STOP)/Modify address	1 Orange	+24VDC	RJ45 right port of ion bar Green light indicates positive high voltage working and orange light indicates negative high voltage working, which flash alternately with the operating frequency.
1: 0.1HZ	2 White-orange	+24VDC	
2: 0.5HZ	3 Blue	RS485+B	RJ45 left port of ion bar Green light indicates power-on, and orange light flashing displays communication status.
3: 1HZ	4 White-blue	RS485+A	
4: 5HZ	5 Green	0V	
5: 10HZ	6 White-green	0V	
6: 30HZ	7 Brown	HV _{AL} : Eliminator high voltage alarm	
7: 55HZ	8 white-brown	ACT: Eliminator power-on indication Clean: Eliminator cleaning indication	
8: 65HZ	9 Metal shield	PE	
9: 105HZ	The output wiring diagrams of pins 7 and 8 are as follows:		
A: 105HZ			
B: 105HZ			
C: IR/PC Frequency can be set by the remote contro (For fixed frequency switching)			
D: IR/PC Frequency can be set by the remote contro (For fixed frequency switching)			
E: Negative high-voltage output (N:95%、P:5%-105HZ)			
F: Positive high-voltage output (P:95%、N:5%-105HZ)			

Product Specifications

Product Details / Product Parameter / Product Size

◆ Product Size

Unit: mm

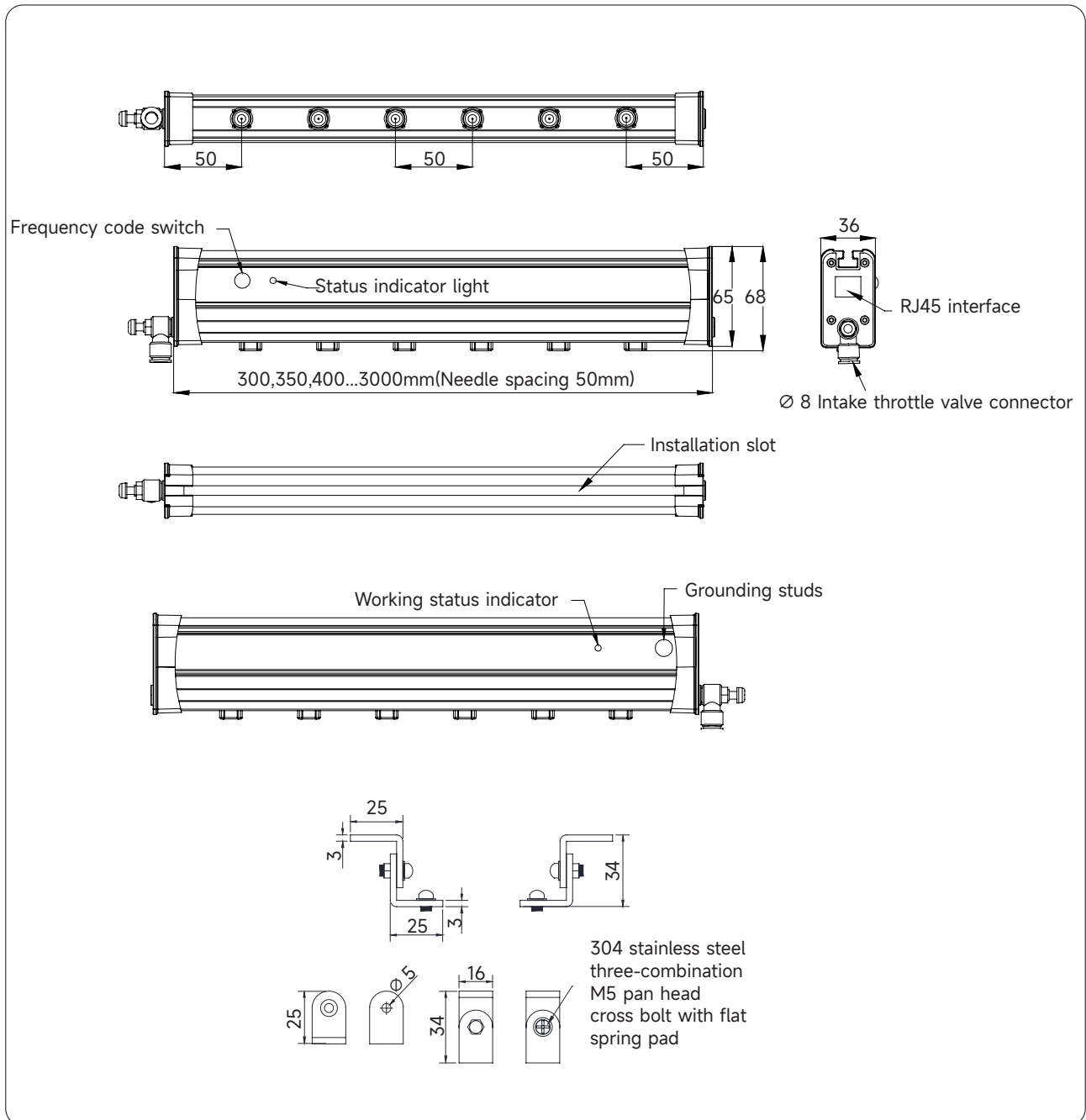

Product Specifications

Product Details / Product Parameter / Product Size

◆ Product Parameter

Model	AP-AB1228
Input voltage	DC 24V
Input current	< 600mA
Power	10W
Working voltage	±4000V~±7000V
Ion emission	Pulse AC
Emitter electrode	Tungsten
Discharge structure	Resistance coupling
Output frequency	0.1,0.5,1,5,10,30,55,65,105Hz; (EX-Work setting: 55Hz)
Discharge range	L*W*H: Bar Length *300*1000mm
Installation distance	100 → 1000mm
Ion balance	≤ ±30V (AVG)
Discharge time	≤ 2S (Working distance 300mm)
Working status	Green light - normal, Blue light - standby, Blue light flashing—debugging /cleaning, Red light - Abnormal high voltage
Network port function	The left port is the power/communication port.(Indicator status: Green light on, power-on indication; Orange light on (blinking) indicates communication) The right port is the power port.(Indicator status: orange and green light flashing alternately with working frequency)
Status monitoring	RS485 communication (115200bps,8,1,n,n) (≥ 30ms) Collector open circuit: (< 50V/100mA)
Airflow pressure	≤ 0.6MPa
Intake throttle valve connector	G1/8 for φ8 pipe diameter
Working temperature	0°C -50°C
Working humidity	< 70%
Dimensions	L*W*H: {300-3000 (Needle spacing 50mm) }*36*68.2mm
Product material	Flame retardant PVC, AL, SUS
Installation accessories	180° rotary install bracket、 M5x12pan head Phillips screw、 M5 Hex nuts、 steel flat gasket、 spring washer、 1m Yellow-Green ground wire
Supporting power supply	GRT-240200: INPUT: 100—240VAC 50/60Hz; OUTPUT: 24VDC 2000mA dual network port output L*W*H: 123*61*40.5mm
length of supporting power network cord	2.5m
Warranty	1 Year
Certification	CE / RoHS

Use of the product

Installation Step / Installation Position / Packaging Accessories

◆ Installation Step

01

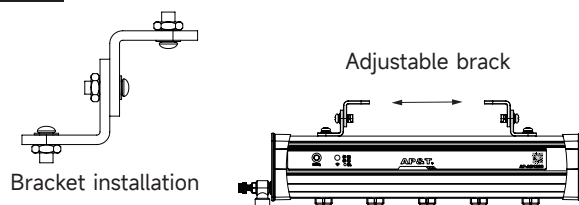

- ▶ Take out the ion bar, adapter power supply, power supply network cable, stainless steel mounting brackets and other accessories from the packing box.
- ▶ Install the stainless steel mounting brackets on the base mounting slot on the ion bar.

02

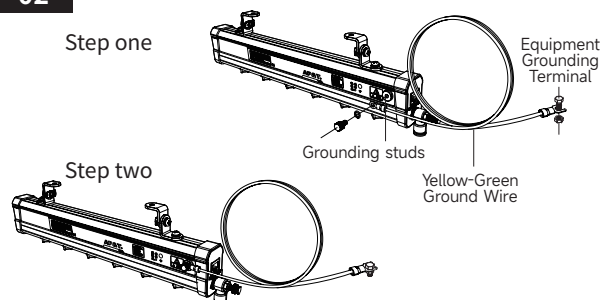

- ▶ Connect one end of the yellow-green ground wire to the grounding bolt of the ion bar and the other end to the AC equipment ground.

03

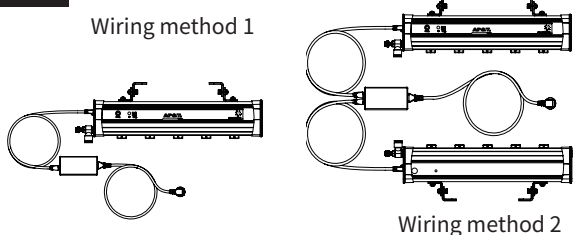

- ▶ Insert one end of the power cord into the RJ45 socket of the power adapter and the other end into the power RJ45 socket on the bar body. One adapter can connect up to two ion bars.

04

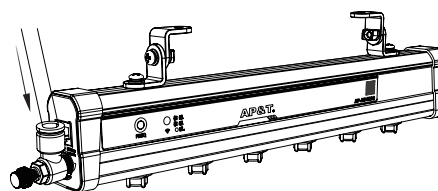

- ▶ Connect the air source connector on the bar body to the air source generating device, turn on the air source switch and control the maximum operating pressure of the compressed air flow to avoid malfunction of the ion bar.

05

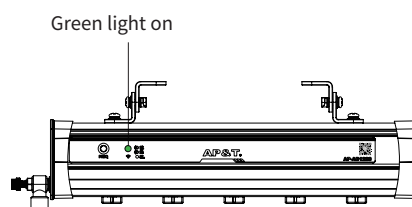

- ▶ The indicator light of the adapted power supply is on, and the indicator light of the ion bar panel is green, indicating normal operation of the ion bar.

06



- ▶ The voltage output parameters are adjusted with the remote control at the appropriate airflow pressure.
- ▶ When the positive voltage on the surface of the flat panel detector or the object to be discharged is large, press to adjust "IB-"; when the negative voltage on the flat panel detector or the surface of the object to be discharged is large, press "IB+" to adjust until the balance is adjusted to the ideal status.

Use of the product

Installation Step / Installation Position / Packaging Accessories

◆ Installation Position

- Place the ion bar in the work area where static electricity is to be eliminated and the installation angle is perpendicular to the surface of the charged body. The working frequency and installation distance can refer to the following table according to the respective electrostatic safety and process control requirements. (Ex-work setting is 55Hz. Please refer to the instructions of operating parameter and coding switch on the panel if you need to adjust the output frequency. Configure a plate tester if you want to see the adjustment results.)

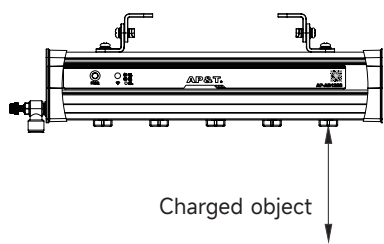

Working frequency (Hz)	Installation distance (mm)	Corresponding site
105	100-300	Low balance required such as optoelectronics, semiconductor devices, hard disks, etc.
55	300-400	Low balance required such as optoelectronic devices
30	300-600	Fast moving objects such as films; Low balance required such as electronic devices
10	600-800	Material filling and transfer
5	800-1000	Discharge at a long distance

Schematic diagram of working frequency-discharge distance

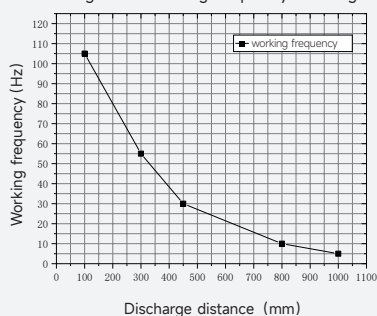

Schematic diagram of working frequency-discharge time

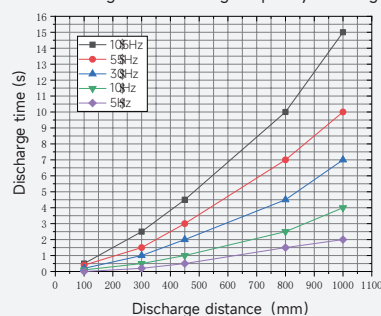

- Ion bar strip grounding electrode is not allowed to be covered by other objects.
- Two ion bars should be installed side by side with an interval of more than 300mm.

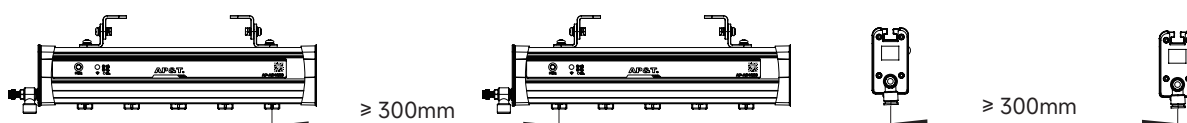



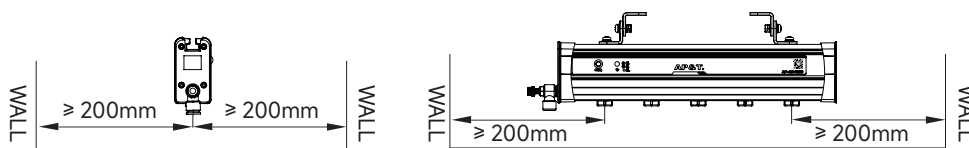



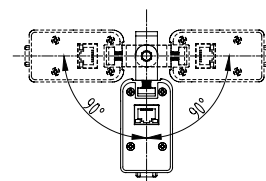
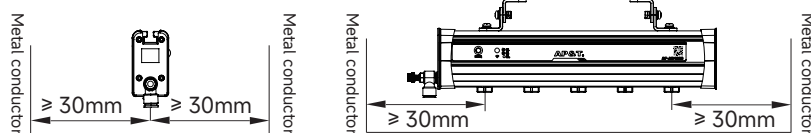









- More than 200mm away from obstacles such as walls.



- Ion bar should be at least 30mm away from the metal conductor and metal grounding body around the electrode and the bar body must be reliably connected to the ground wire.
- The mounting angle of ion bar can be adjusted.



◆ Packaging accessories

Name	Picture	Part No.	Specification	Quantity
Power Adapter		AP2930003	GRT-240200 DC24V 2A P/N:1/2+ 5/6- Port metal PE	1
National standard power cord		8YXG25110	Standard:1.8m, optional:3m/5m	1
Double ended crystal head black shield cable		8WXI00004	Standard:2.5m, 5m/10m:optional	1
Single-ended crystal head black shield cable		8WXI00002	FFUTP CAT.5E 26AWG 4Pair Jacket PVC OD:5.6±0.2mm bag packed	optional
L-shaped stainless steel mounting bracket		AP8038005	Height 25mm/Width 16mm/ Thickness 3mm Aperture 5mm (measured 4.8mm)	4
Square nut		AP8933000	M5*12*12*4	2
304 stainless steel spring washer		AP8943000	M5	6
304 stainless steel flat gasket		AP8946004	M5	6
304 stainless steel pan head Phillips screw		AP8900001	M5*12	6
Hex nuts		1LML05000	M5	4
Intake throttle valve		3JTQF0801	Standard:8mm, optional:6mm	1
Needle holder		AP6620003	—	—
Remote control		AP2253011	Infrared remote control, neutral panel (L*W*H : 85.76*39.76*6.66)	1
Yellow - green ground wire		AP6640072	Wire diameter 0.5mm ² , length 1000mm, 4.2mm grounding lug at one end and a 4mm U-shaped terminal at the other end	1
Spring washer		1TD004000	M4	1
304 hand screw single head knurling		AP8906016	M4*5	1

▲ Safety warning

- Please read the instruction manual carefully before installing and using this equipment.
- The whole set of equipment must be reliably grounded during use, otherwise it is easy to cause abnormality or even damage to the ion bar.
- Do not use this equipment in environment where humidity is > 70%.
- It is strictly forbidden to use this equipment in flammable and explosive environments.

- Unauthorized disassembly of the product is strictly prohibited, internal maintenance and repair must be performed by professionals.
- The product is strictly prohibited to touch liquid during use, otherwise an abnormality may occur and cause electric shock or fire.
- Power must be turned off during inspecting or replacing the product, otherwise it may cause electric shock or fire.
- The product is ventilated with dry and clean air or nitrogen which will work abnormally or be damaged if the gas source contains water or grease.
- The product is specially designed to eliminate static electricity. It is strictly forbidden to use it for other purposes. Any abnormal use may cause machine failure, electric shock, fire and other accidents.
- Its strictly forbidden to touch the electrode needles when power is on, otherwise it is easy to cause malfunctions and electric shock accidents.
- The electrode needle is a sharp metal object, please use it with care.
- Please check the specifications of the power supply before powering on the product. Any power supply that does not meet the specifications will cause damage to the product.
- Please check the product power cord/communication cord regularly and replace it immediately if it is damaged. Otherwise it is easy to cause problems such as electric leakage, poor communication, and abnormal operation.

▲ Trouble shooting

NO.	Problems	Reasons	Solutions
1	The indicator on the panel is off	Poor contact of the power cable	Check whether the power cable is in good condition and securely connected
		Power supply mismatch	Confirm the power supply specification (INPUT: 100—240VAC 50/60Hz; OUTPUT: 24VDC 2000mA)
2	The indicator on the left port is off	Poor contact of power cable	Check whether the power cable is in good condition and securely connected
		Power mismatch	Confirm the power supply specification (INPUT: 100—240VAC 50/60Hz; OUTPUT: 24VDC 2000mA)
		No power supply, power indicator--green light is off	Check the power supply line
		No communication connection or communication failure, communication indicator - orange light is off	Check communication connection and software setup
3	The indicator on the right port is off (normally blinks alternately with the working frequency)	Poor contact of power cable	Check whether the power cable is in good condition and securely connected
		Power supply mismatch	Confirm the power supply specification (INPUT: 100—240VAC 50/60Hz; OUTPUT: 24VDC 2000mA)
		Working mode is incorrect -- only green light is on (positive high voltage only)	Unplug the power cord and restart the ion bar. Or reset the working frequency (this lamp is not used to judge the failure of the high voltage module)
		Working mode is incorrect -- only orange light is on (negative high voltage only)	
		The duty ratio is too small and the green light is dark	Adjust duty ratio until ion balance becomes good. Return to factory for repair if adjustment is not effective.
The duty ratio is too high and the orange light is dark			
4	The electrostatic removal performance decreased obviously	Discharge needle is polluted and damaged	Clean or replace the discharge needle
		Whether the discharge seat is tightened	Confirm the discharge seat is tightened
		Ion bar positioning is incorrect	Confirm the best installation location
5	The electrostatic removal performance decreased	There are conductors or other ion bar around	Remove (moving) conductors or other ion bar
6	Panel indicator red light on	Electromagnetic interference	Turn off the power switch / unplug the power cable, restart the ion bar
		Abnormal discharge	Confirm the installation location and stay away from surrounding conductors
		No power supply for high voltage module	Return to factory for maintenance
		High voltage module is damaged	

7	Panel indicator blue light flashes	Poor grounding of the strip grounding electrodes on both sides of the electrode needle at the bottom of the ion bar	Return to factory for maintenance
8	Unable to discharge	High voltage module is damaged	
		Main-board chip is damaged	
		Main-board chip is damaged caused by poor grounding or no grounding	Check the grounding of the ion bar and plant equipment, and return to the factory for maintenance
9	The product is smoky or burnt	High voltage module is damaged or insulation of the discharge seat is damaged	Return to factory for maintenance

▲ Maintenance

- The ion bar should be cleaned and maintained in time according to the use environment and the required electrostatic protection requirements in order to ensure the good performance of the product. That is, gently remove the carbon deposits on the discharge electrode, discharge socket, and metal discharge body with electrostatic brush, dust-free cotton swab, dust-free cloth dipped in anhydrous alcohol, which will improve its performance significantly. Note:

A. Operation must be done 10 minutes after power cut off.

B. It must be cleaned when dust or white products appear on the tip of the needle during use. Use dust-free cloth dipped in anhydrous alcohol to clean when brush can not meet the cleaning requirements.

C. The ion bar must be powered on after alcohol is completely volatilized after cleaning. No other organic solvent can be used to clean the ion bar.

- If the switch working indicator light of the power plug-in port on the panel of the ion bar is off , it should be stopped and repaired by professional maintenance personnel. It can be used only after the electrical performance index is normal.

▲ After-sales service

- AP-AB1228 intelligent self-balancing static removal ion bar has undergone rigorous testing and aging treatment before ex-work. Its performance has completely reached the relevant indicators marked in the usage instruction.
- AP&T makes a commitment to the customer that any defective parts inspected by AP&T will be repaired or replaced free of charge within one year from the date of purchase. However, this commitment does not apply to:

(1)、The device is incorrectly used or installed.

(2)、Damage caused by negligence or accident during use.

(3)、Modified, disassembled or repaired by other service departments not authorized by Anping Company.

- The alloy electrode is a consumable product which is not included in the scope of warranty and will be charged for replacement when repairing.
- AP&T shall not be liable for any incorrect use of the products except for repair or replacement of parts as specified above.

AP&T®

AP&T®

SPECIALITY CREATES VALUE

Professional electrostatic intelligent monitoring/analysis
and elimination solution provider

Shanghai Anping Static Technology Co.,Ltd

Tel: 021-6451 7676

Website: www.ap-static.com

Address: 3-4/F, Building 27, No.69, Guiqing Road, Shanghai, China

